

**American National Standard
Requirements for Sealed Dry-Type
Power Transformers, 501 kVA and Larger, Three-Phase,
with High-Voltage 601 to 34 500 Volts,
Low-Voltage 208Y/120 to 4160 Volts**

Secretariat

**Institute of Electrical and Electronics Engineers
National Electrical Manufacturers Association**

Approved December 22, 1980

American National Standards Institute, Inc

Published by

**American National Standards Institute
1430 Broadway, New York, N.Y. 10018**

Copyright © 1981 by American National Standards Institute, Inc
All rights reserved.

**No part of this publication may be reproduced in any form, in an electronic retrievals system or otherwise,
without the prior written permission of the publisher.**

Printed in the United States of America

A1¹/₂M681/5

American National Standard

An American National Standard implies a consensus of those substantially concerned with its scope and provisions. An American National Standard is intended as a guide to aid the manufacturer, the consumer, and the general public. The existence of an American National Standard does not in any respect preclude anyone, whether he has approved the standard or not, from manufacturing, marketing, purchasing, or using products, processes, or procedures not conforming to the standard. American National Standards are subject to periodic review and users are cautioned to obtain the latest editions.

CAUTION NOTICE: This American National Standard may be revised or withdrawn at any time. The procedures of the American National Standards Institute require that action be taken to reaffirm, revise, or withdraw this standard no later than five years from the date of publication. Purchasers of American National Standards may receive current information on all standards by calling or writing the American National Standards Institute.

Foreword

(This Foreword is not a part of American National Standard Requirements for Sealed Dry-Type Power Transformers, 501 kVA and Larger, Three-Phase, with High-Voltage 601 to 34 500 Volts, Low-Voltage 208Y/120 to 4160 Volts, ANSI C57.12.52-1981.)

This new dry-type transformer standard describes sealed dry-type transformers with self-cooled kilovolt-ampere ratings 501 to 5000 and high voltages 601 to 34 500 volts. (American National Standards Committee on Specialty Transformers, C89, has responsibility for transformers with high voltages 600 volts and below.) It is part of a new series of dry-type standards which also includes American National Standard General Requirements for Dry-Type Distribution and Power Transformers, ANSI/IEEE C57.12.01-1979; American National Standard Test Code for Dry-Type Distribution and Power Transformers, ANSI/IEEE C57.12.91-1979; American National Standard Requirements for Ventilated Dry-Type Distribution Transformers, 1 to 500 kVA, Single-Phase, and 15 to 500 kVA, Three-Phase, with High-Voltage 601 to 34 500 Volts, Low-Voltage 120 to 600 Volts, ANSI C57.12.50-1981; and American National Standard Requirements for Ventilated Dry-Type Power Transformers, 501 kVA and Larger, Three-Phase, with High-Voltage 601 to 34 500 Volts, Low-Voltage 208Y/120 to 4160 Volts, ANSI C57.12.51-1981.

Dry-type transformers have been served in the past by a variety of documents, including American National Standard General Requirements for Distribution, Power, and Regulating Transformers, ANSI C57.12.00-1973; American National Standard Test Code for Distribution, Power, and Regulating Transformers, ANSI C57.12.90-1973; American National Standard Dry-Type Transformers for General Applications, ANSI/NEMA ST 20-1972; and NEMA Standards Publication for Commercial, Institutional, and Industrial Dry-Type Transformers, NEMA TR 27-1965 (R1976). The new standards are the result of an effort encompassing the interests of users, manufacturers, and others dedicated to developing voluntary consensus standards primarily for dry-type transformers. They have various significant changes, including higher BILs (for most voltages), more stringent and meaningful short-circuit requirements, improved descriptions of “usual” and “unusual” service conditions, and numerous other improvements. These new standards should be easier and more efficient to use since they are arranged according to the sequence in which information is normally needed. ANSI C57.12.52-1981 includes customary units and metric (SI) units in accordance with ANSI policy. Sound levels were discussed in the preparation of this standard, but are not included at present. As a matter of information, NEMA TR 1-1980, Transformers, Regulators, and Reactors, includes data concerning dry-type transformer sound levels.

This standard is a voluntary consensus standard. Its use is mandatory only when required by a duly constituted legal authority or when specified in a contractual relationship. To meet specialized needs and to allow innovation, specific changes are permissible when mutually determined by the user and the producer, provided such changes do not violate existing laws and are considered technically adequate for the function intended.

When this document is used on a mandatory basis, the word “shall” indicates mandatory requirements, and the words “should” and “may” refer to matters that are recommended and permissive, respectively, but not mandatory.

The applicable ANSI rules and procedures for the preparation and approval of voluntary consensus standards have been followed. These specify procedures for voting, review and attempted reconciliation of dissenting viewpoints, a 60-day public review period, and final review and approval by the ANSI Board of Standards Review.

Suggestions for improvement of this standard will be welcome. They should be sent to the American National Standards Institute, Inc, 1430 Broadway, New York, N.Y. 10018.

This standard was processed and approved for submittal to ANSI by American National Standards Committee on Transformers, Regulators, and Reactors, C57. Committee approval of the standard does not necessarily imply that all committee members voted for its approval. At the time it approved this standard, the C57 Committee had the following members:

I. H. Koponen, Chair
C. R. Willmore, Secretary

<i>Organization Represented</i>	<i>Name of Representative</i>
Bonneville Power Administration.....	G. W. Iliff
Electric Light and Power Group	R. R. Bast R. L. Ensign I. H. Koponen J. P. Markey (<i>Alt</i>) B. F. Smith E. A. Villasuso, Jr
Institute of Electrical and Electronics Engineers	S. Bennon J. C. Dutton D. C. Johnson L. W. Long D. E. Massey R. L. Simpson
National Electrical Manufacturers Association	L. C. Aicher W. R. Courtade J. W. Dix J. D. Douglass W. C. Kendall K. Lindsley (<i>Alt</i>) W. J. McNutt N. M. Neagle (<i>Alt</i>) R. L. Schwab R. J. Stahara (<i>Alt</i>) R. E. Uptegraff, Jr
Naval Facilities Engineering Command	H. P. Stickley
Rural Electrification Administration.....	J. C. Arnold, Jr
Tennessee Valley Authority.....	L. R. Smith
Underwriters Laboratories	W. A. Farquhar (<i>Alt</i>) E. J. Huber
U.S. Bureau of Reclamation	S. J. Baxter
U.S. Department of Energy	M. Smith, Jr

Subcommittee C57.12.5 on Dry-Type Transformers, which developed this standard, had the following members:

John C. Dutton, Chair
Charles H. White, Secretary

B.F. Allen (<i>Alt</i>)	R. Endicott	J. J. Nay (<i>Alt</i>)
L. G. Ananian (<i>Alt</i>)	H. E. Gabel, Jr	W. J. Neiswender
R. Bancroft	R. H. Hollister (<i>Alt</i>)	R. E. Rothrock
J. A. Berseth	P. Hopkinson	R. L. Simpson
D. R. Brown	E. J. Huber	S. G. Vargo
F. J. Brutt	F. J. Klecic (<i>Alt</i>)	E. Villasuso, Jr
C. C. Dixon	N. J. Melton	S. A. Wiencek
	M. Mingoia (<i>Alt</i>)	

CLAUSE	PAGE
1. Scope.....	1
1.1	1
1.2	1
1.3	1
1.4	1
1.5	2
2. Related Standards and Guides.....	2
2.1 General	2
2.2 Terminology.....	3
2.3 Revision of American National Standards Referred to in This Document.....	3

Part I: Basic Electrical and Mechanical Requirements

3. Usual Service Conditions.....	3
4. Ratings and Characteristics	3
4.1 Kilovolt-Ampere Ratings	3
4.2 Kilovolt-Ampere and Voltage Ratings	3
4.3 Taps.....	4
4.4 Insulation Levels.....	4
4.5 Angular Displacement and Terminal Markings.....	5
4.6 Percent Impedance Voltage	6
5. Construction	6
5.1 Insulation System.....	6
5.2 Accessory Location.....	6
5.3 Nameplate	7
5.4 Transformer Connections.....	7
5.5 Tap Changer.....	8
5.6 Temperature Indication	8
5.7 Pressure-Vacuum Gage.....	9
5.8 Shutoff Valve	9
5.9 Filling Valve	9
5.10 Tank	9
6. Routine Tests.....	11
7. Tolerances	11

Part II: Other Requirements or Alternatives That May Be Specified for Some Applications

8. Other Ratings and Characteristics.....	11
8.1 Other Ambient Temperature Conditions.....	11
8.2 Other Winding Temperature Rises	12
8.3 Other Insulation Systems	12
8.4 Other High-Voltage Ratings and Connections.....	12

CLAUSE	PAGE
8.5 Y-Y Connected Transformers	14
8.6 Increased Neutral Insulation	16
8.7 Other Basic Lightning Impulse Insulation Levels (BILs).....	16
9. Other Construction	16
9.1 High-Voltage Connection Arrangements.....	16
9.2 Low-Voltage Connection Arrangements	17
9.3 Surge Arresters.....	17
9.4 Unit Substation Application.....	17
9.5 Pressure Alarm Switch.....	17
9.6 High-Temperature Alarm Switch.....	18
9.7 Current Transformers (or Provision for Their Addition in the Future).....	18
9.8 Terminal Blocks.....	18
9.9 Contacts.....	18
10. Other Tests	18

American National Standard Requirements for Sealed Dry-Type Power Transformers, 501 kVA and Larger, Three-Phase, with High-Voltage 601 to 34 500 Volts, Low-Voltage 208Y/120 to 4160 Volts

1. Scope

1.1

This standard is intended to set forth characteristics relating to performance, limited electrical and mechanical interchangeability, and safety of the equipment described, and to assist in the proper selection of such equipment.

1.2

This standard describes certain electrical and mechanical characteristics and takes into consideration certain safety features of 60-Hz, two-winding, three phase, sealed dry-type transformers rated 501 kVA and larger, generally used for step-down purposes.

Specific rating combinations are described in the range from 750 to 5000 kVA inclusive, with high-voltage 2400 to 34 500 volts inclusive and low-voltage 208Y/120 to 4160 volts inclusive.

1.3

This standard does not apply to other types of transformers, such as specialty, ventilated dry-type, pad-mounted dry-type, liquid immersed, instrument, regulating, furnace, mine, and rectifier transformers.

1.4

When this document is used on a mandatory basis, the word “shall” indicates mandatory requirements, and the words “should” and “may” refer to matters that are recommended and permissive, respectively, but not mandatory.

NOTE — The Foreword of this standard describes the circumstances under which the document may be used on a mandatory basis.

1.5

Part I of this standard describes basic electrical and mechanical requirements. Part II describes other requirements or alternatives which may be specified for some applications.

2. Related Standards and Guides

2.1 General

All requirements, definitions, and tests, except as specifically covered in this standard, shall be in accordance with the American National Standards listed below (see 2.3). When referred to in this document, standards are identified by designation and year (for example, ANSI/IEEE C57.12.01-1979).

American National Standard for Unified Inch Screw Threads (UN and UNR Thread Form), ANSI B1.1-1974

American National Standard for Pipe Threads (except Dryseal), ANSI B2.1-1968

American National Standard Requirements for Ventilated Dry-Type Distribution Transformers, 1 to 500 kVA, Single-Phase, and 15 to 500 kVA, Three-Phase, with High-Voltage 601 to 34 500 Volts, Low-Voltage 120 to 600 Volts, ANSI C57.12.50-1981

American National Standard Requirements for Ventilated Dry-Type Power Transformers, 501 kVA and Larger, Three-Phase, with High-Voltage 601 to 34 500 Volts, Low-Voltage 208Y/120 to 4160 Volts, ANSI C57.12.51-1981

American National Standard Terminal Markings and Connections for Distribution and Power Transformers, ANSI C57.12.70-1978

American National Standard Guide for Installation and Maintenance of Dry-Type Transformers, ANSI Appendix C57.94 (1958)

American National Standard Guide for Application of Valve-Type Lightning Arresters for Alternating Current Systems, ANSI C62.2-1980

American National Standard Voltage Ratings for Electric Power Systems and Equipment (60 Hz), ANSI C84.1-1977 and C84.1a-1980

American National Standard General Requirements for Dry-Type Distribution and Power Transformers, ANSI/IEEE C57.12.01-1979

American National Standard Terminology for Distribution and Power Transformers, ANSI/IEEE C57.12.80-1978

American National Standard Test Code for Dry-Type Distribution and Power Transformers, ANSI/IEEE C57.12.91-1979

American National Standard Requirements for Instrument Transformers, ANSI/IEEE C57.13-1978

American National Standard Guide for Application of Transformer Connections in Three-Phase Distribution Systems, ANSI/IEEE C57.105-1978

American National Standard Dictionary of Electrical and Electronics Terms, ANSI/IEEE 100-1977

2.2 Terminology

Standard transformer terminology as set forth in ANSI/IEEE C57.12.80-1978 shall apply. Other electrical terms are defined in ANSI/IEEE 100-1977.

2.3 Revision of American National Standards Referred to in This Document

When an American National Standard referred to in this document is superseded by a revision approved by the American National Standards Institute, Inc, the revision shall apply.

Part I: Basic Electrical and Mechanical Requirements

(See Part II for other requirements or alternatives that may be specified for some applications.)

3. Usual Service Conditions

Service conditions shall be in accordance with those described in ANSI/IEEE C57.12.01-1979.

4. Ratings and Characteristics

4.1 Kilovolt-Ampere Ratings

4.1.1

Kilovolt-ampere ratings are continuous and based on not exceeding a 150°C average winding temperature rise, as measured by resistance (220°C limiting temperature).

4.1.2

Self-cooled (GA) kilovolt-ampere sizes shall be 750, 1000, 1500, 2000, 2500, 3750, and 5000 kVA.

4.2 Kilovolt-Ampere and Voltage Ratings

Kilovolt-ampere and voltage ratings for three-phase self-cooled (GA) transformers shall be as shown in Table 1.

NOTE — At voltages 15 kV and above, Y–Y design transformers (described in Part II of this standard) may be required by utility users because of special system requirements.

Table 1— Range of Kilovolt-Ampere and Voltage Ratings for Three-Phase (GA) Transformers

Rated High-Voltage (volts)	Kilovolt-Ampere Rating (kVA)		
	Low Voltage 208Y/120	Low Voltages 480,480Y/277	Low Voltages 2400, 4160GrdY/2400, 4160
2 400	750–1000	750–1500	–
4 160	750–1000	750–1500	–
4 800	750–1000	750–1500	–
6 900	750–1000	750–2500	–
7 200	750–1000	750–2500	–
12 000	750–1000	750–2500	750–5000
13 200	750–1000	750–2500	750–5000
13 800	750–1000	750–2500	750–5000
23 000	750–1000	1000–2500	1500–5000
34 500	750–1000	1000–2500	1500–5000

NOTES:

1 — All voltages are Δ unless otherwise indicated.

2 — Kilovolt-ampere ratings separated by a dash indicate that all intervening ratings specified in 4.1.2 are included.

4.3 Taps

Four high-voltage winding rated kilovolt-ampere taps shall be provided as follows: two 2.5% taps above rated voltage, and two 2.5% taps below rated voltage.

4.4 Insulation Levels

High-voltage line terminal insulation levels shall be as shown in Table 2. Low-voltage line terminal insulation levels shall be as shown in Table 3.

Table 2— High-Voltage Line Terminal Insulation Levels

Rated High Voltage (volts)	Basic Lightning Impulse Insulation Level (BIL) (kV)	Low-Frequency Voltage Insulation Level (kV, rms)
2 400	20	10
4 160	30	12
4 800	30	12
6 900	30	12
7 200	30	12
12 000	60	31
13 200	60	31
13 800	60	31
23 000	110	37
34 500	150	50

NOTE — All voltages are Δ unless otherwise indicated.

Table 3— Low-Voltage Line Terminal Insulation Levels

Rated Low Voltage (volts)	Basic Lightning Impulse Insulation Level (BIL) (kV)	Low-Frequency Voltage Insulation Level (kV, rms)
208Y/120	10	4
480	10	4
480Y/277	10	4
2400	20	10
4160GrdY/2400	20	10
4160	30	12

NOTES:

- 1 — All voltages are Δ unless otherwise indicated.
- 2 — Neutrals are insulated for low-frequency applied voltage test equal to that of the winding line terminal or 10 kV, whichever is lower.

4.5 Angular Displacement and Terminal Markings

4.5.1 Angular Displacement

The angular displacement between high-voltage and low-voltage terminal voltages of three-phase transformers with Δ - Δ connections shall be 0 degrees.

The angular displacement between high-voltage and low-voltage terminal voltages of three-phase transformers with Δ -y connections shall be 30 degrees, with the low voltage lagging the high voltage as shown in Fig. 1; phasor relations shall be as shown in Fig. 1.

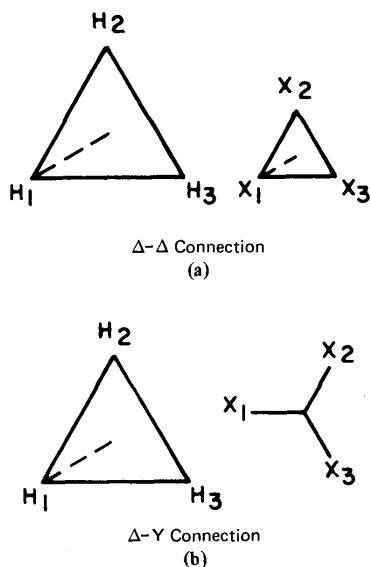

Figure 1— Angular Displacement

4.5.2 External Terminal Designations

Terminal designations shall be in accordance with ANSI C57.12.70-1978.

4.6 Percent Impedance Voltage

The preferred percent impedance voltage at the self-cooled rating as measured on the rated voltage connection shall be as shown in Table 4.

Table 4— Percent Impedance Voltage

High Voltage BIL (kV)	Low Voltage	
	600 Volts and Below	2400 Volts and Above
60 and below	5.75	5.75
Above 60	See Note	See Note

NOTE — In view of the relatively little experience that industry has had in building and applying dry-type transformers above 15 kV high voltage, no consensus regarding standard values of impedance has yet been established. Such impedances should be determined by discussion between users and manufacturers until experience is available to determine consensus values.

5. Construction (See Fig. 2)

5.1 Insulation System

5.1.1

The insulation system of the transformer shall be suitable for operation at the limiting temperature associated with the kilovolt-ampere rating (see 4.1.1).

5.1.2

The transformer shall be filled with an insulating gas suitable for operation at the limiting temperature, and with properties such that it will maintain adequate insulating and heat transfer properties at -30°C minimum ambient temperature.

5.2 Accessory Location

Preferred locations of accessories, connections, compartments, and the like are given in Fig. 2 and its referenced paragraphs.

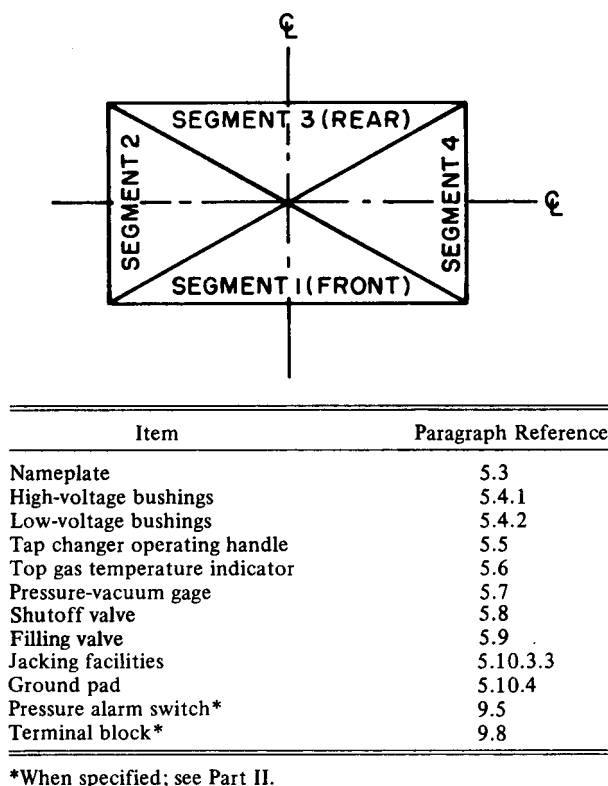

Figure 2— Accessory Location Top (Plan) View

5.3 Nameplate

A nameplate shall be provided in accordance with the requirements of ANSI/IEEE C57.12.01-1979 and shall be located on the front wall in segment 1.

5.4 Transformer Connections

5.4.1

High-voltage line bushings shall be located in segment 2.

5.4.2

Low-voltage line bushings shall be located in segment 4.

5.4.3

The low-voltage neutral shall be a bushing insulated for the appropriate low-frequency voltage insulation level shown in Table 3.

When a grounded-Y winding is involved, the connection from the neutral terminal to ground shall be furnished by the manufacturer as a part of the associated equipment such as switchgear or terminal compartments. (See 9.1.3, 9.1.4, 9.1.5, 9.2.3, 9.2.4, and 9.2.5.)

5.5 Tap Changer

A tap changer for de-energized operation shall be provided with the operating handle brought out through the cover, or through the sidewall in segment 1, at a height convenient for the design.

The tap changer handle shall have provision for padlocking and shall provide visible indication of the tap position without unlocking. A 3/8-inch (9.5-mm) minimum diameter hole shall be provided for the padlock.

The tap changer position indicating plate, shall be marked with letters or Arabic numerals in sequence. The letter "A" or the Arabic numeral "1" shall be assigned to the voltage rating providing the maximum ratio of transformation.

NOTE — The ratio of transformation is the rated voltage of the high-voltage winding divided by the rated voltage of the low-voltage winding.

5.6 Temperature Indication

5.6.1 Top Gas Temperature Indicator

A dial-type thermometer shall be mounted on the side of the tank near the top in segment 1. The thermometer shall be direct-stem-mounted in a closed well at a level suitable for indicating the top gas temperature. For dimension of the well, see Fig. 3.

The thermometer shall have a dark face dial with light markings, a light-colored indicating hand, a contrasting color maximum indicating hand, and provision for resetting.

The diameter of the dial (inside bezel) shall be 4-1/2 inches (114 mm) ± 1 inch (25.4 mm). The dial markings shall cover the range from 0°C to 220°C.

The words "top gas temperature indicator" shall be on the dial or on a suitable nameplate mounted adjacent to the indicator.

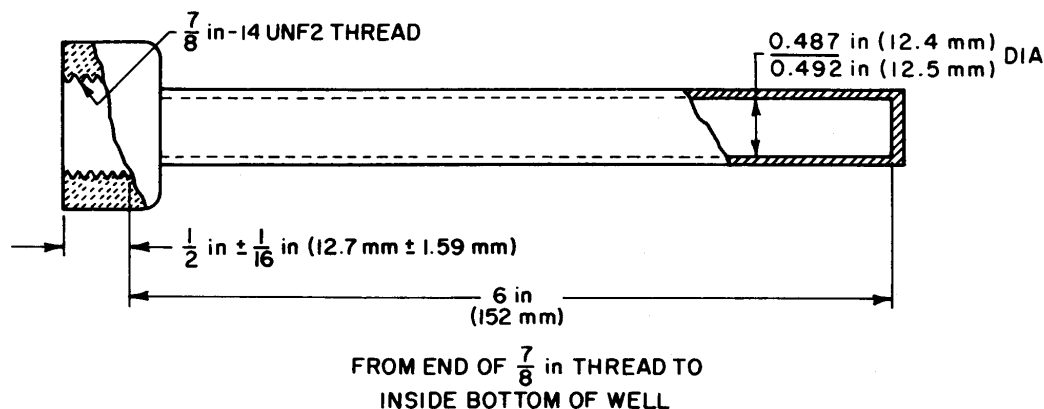

Figure 3— Dimensions of Thermometer Well

5.6.2 Winding Temperature Simulator

When specified, a winding-temperature simulator shall be provided.

5.7 Pressure-Vacuum Gage

A pressure-vacuum gage shall be provided. If a dial gage is furnished, the minimum diameter of the dial (inside bezel) shall be 3-1/2 inches (88.9 mm). The dial and pointer of the gage shall utilize contrasting colors for visibility. The gage shall be located on the front wall in segment 1. It shall be threaded with a 1/4-inch NPT thread in accordance with ANSI B2.1-1968.

5.7.1

For transformers insulated with dielectric gases other than nitrogen or dry air, the scale of the pressure-vacuum gage shall cover the range between 15 psi (103 kPa) positive and 15 psi (103 kPa) negative.

5.7.2

For transformers insulated with nitrogen or dry air, the scale of the pressure-vacuum gage shall cover the range between 10 psi (68.9 kPa) positive and 10 psi (68.9 kPa) negative.

5.8 Shutoff Valve

Transformers insulated with dielectric gases other than nitrogen or dry air shall have a shutoff valve, which shall be located between the tank and pressure- or vacuum-related accessory such as the pressure-vacuum gage and similar devices) to allow their removal for testing or replacement without loss of gas.

5.9 Filling Valve

The tank shall be equipped with a filling valve to permit gas to be added and removed. The valve shall be supplied with 1/2-inch NPT female threads in accordance with ANSI B2.1-1968 and shall have a pipe plug in the open end. The valve shall be located on the front wall in segment 1.

5.10 Tank

5.10.1 Tank Sealing

The tank shall be hermetically sealed and shall have a welded cover.

5.10.2 Tank Pressure and Vacuum

5.10.2.1

Tanks for transformers insulated with dielectric gases other than nitrogen or dry air shall be suitable for a pressure of 15 psi (103 kPa) gage and for vacuum at least equivalent to 2.7 kPa absolute pressure.

5.10.2.2

Tanks for transformers insulated with nitrogen or dry air shall be suitable for pressure or vacuum of ± 7 psi (± 48.3 kPa) gage.

5.10.3 Lifting, Jacking, and Moving Facilities

5.10.3.1 Safety Factor

Lifting, jacking, and moving facilities shall be designed to provide a safety factor of five or more. The safety factor is the ratio of the ultimate stress of the material used to the working stress. The working stress is the maximum combined stress developed in the lifting, jacking, or moving facilities by the static load of the component being lifted or moved.

5.10.3.2 Lifting Facilities

Lifting facilities shall be provided for lifting the cover separately. Four lifting points shall be provided for lifting the core and coil assembly from the tank, using one lifting cable at each lifting point.

Facilities shall be provided for lifting the complete transformer (with the cover securely fastened in place). Lifting facilities shall be designed for lifting from four points using one lifting cable at each lifting point, and with a maximum cable angle of 30 degrees with respect to the vertical. The bearing surfaces of the lifting facilities shall be free from sharp edges and shall be provided with a hole having a minimum diameter of 0.75 inch (20.6 mm) for guying purposes.

5.10.3.3 Jacking Facilities

Jacking facilities shall be provided in the vicinity of the four corners of the base. For transformers rated above 2500 kVA, jacking clearances shall be in accordance with Fig. 4.

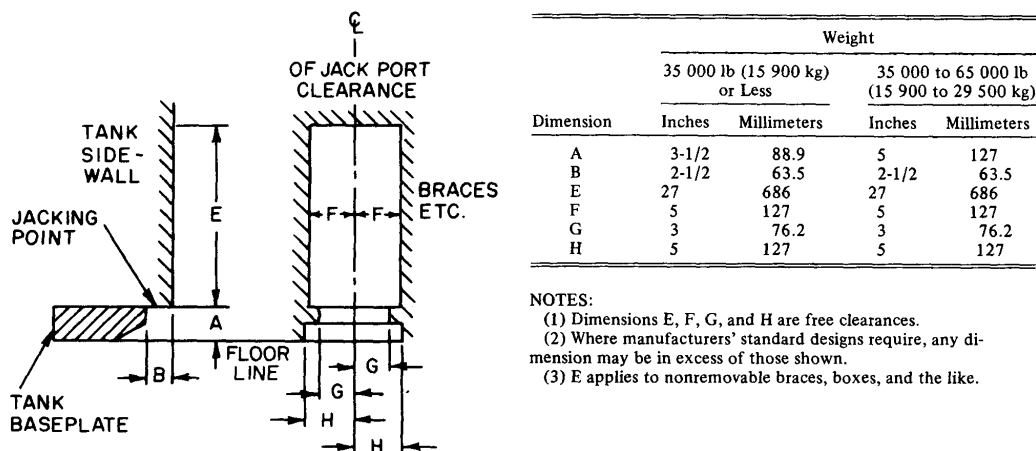

Figure 4— Provision for Jacking (Transformers above 2500 kVA)

5.10.3.4 Base Structure

The base structure shall be designed for moving by rolling or skidding in either direction parallel to the centerlines of the transformer.

5.10.3.5 Tilting

The points of support shall be so located that the center of gravity of the transformer as prepared for shipment will not fall outside these points of support for a tilt of the base of 15 degrees or less from the horizontal.

5.10.4 Ground Pad

Grounding provision shall consist of a pad with a corrosion-resistant metallic surface, 2 inches \times 3-1/2 inches (50.8 mm \times 88.9 mm) with two holes horizontally spaced on 1-3/4-inch (44.5-mm) centers drilled and tapped for 1/2-inch- 13-NC thread, in accordance with ANSI B1.1-1974, and with a minimum thread depth of 1/2 inch (12.7 mm). The ground pad shall be welded to the base or tank structure and should be located at the end of the transformer in segment 4.

6. Routine Tests

Routine tests shall be made in accordance with ANSI/IEEE C57.12.01-1979.

7. Tolerances

Tolerances on ratio, impedance, and losses shall be in accordance with ANSI/IEEE C57.12.01-1979.

Part II: Other Requirements or Alternatives That May Be Specified for Some Applications

(See Part I for basic electrical and mechanical requirements.)

NOTE — Certain specific applications have transformer requirements not covered in Part I. Part II comprises descriptions of the most frequently used requirements for such transformers. They shall be provided only when specified in conjunction with Part I requirements or, where applicable, as alternatives to Part I requirements.

8. Other Ratings and Characteristics

8.1 Other Ambient Temperature Conditions

8.1.1 40°C Average Ambient Temperature Conditions

When specified, the transformer shall be designed for operation in a location in which the maximum temperature of the cooling air (ambient temperature) does not exceed 50°C at any time and the average temperature of the cooling air for any 24-hour period does not exceed 40°C.

When this increased ambient temperature is specified, the kilovolt-ampere continuous rating of 4.1 shall be based on not exceeding a 140°C average winding temperature rise, as measured by resistance (220°C limiting temperature).

8.1.2 Other Minimum Ambient Temperature Conditions

When specified, dielectric insulating gas shall be provided for a minimum ambient temperature lower than the normal -30°C.

8.2 Other Winding Temperature Rises

8.2.1

When specified, the kilovolt-ampere continuous rating shall be based on not exceeding an 80°C average winding temperature rise, as measured by resistance (150°C limiting temperature). When an increased ambient temperature is specified in accordance with 8.1.1, this kilovolt-ampere continuous rating shall be based on not exceeding a 70°C average winding temperature, as measured by resistance (150°C limiting temperature.)

8.2.2

When specified, the kilovolt-ampere continuous rating shall be based on not exceeding a 115°C average winding temperature rise, as measured by resistance (185°C limiting temperature). When an increased ambient temperature is specified in accordance with 8.1.1, this kilovolt-ampere continuous rating shall be based on not exceeding a 105°C average winding temperature rise, as measured by resistance (185°C limiting temperature).

8.3 Other Insulation Systems

8.3.1

When specified, transformers designed for an 80°C average winding temperature rise, as measured by resistance, shall be provided with a 150°C-rise insulation system (220°C limiting temperature), as defined in 5.11.3 of ANSI/IEEE C57.12.01-1979.

8.3.2

When specified, transformers designed for a 115°C average winding temperature rise, as measured by resistance, shall be provided with a 150°C-rise insulation system (220°C limiting temperature), as defined in 5.11.3 of ANSI/IEEE C57.12.01-1979.

8.4 Other High-Voltage Ratings and Connections

8.4.1 High-Voltage Windings without Taps

When specified, the high-voltage winding shall be furnished without taps.

8.4.2 Other High-Voltage Ratings

When specified, high-voltage ratings may be selected within the range of ratings listed in Table 5. These are rated high voltages (line-to-line) and are alternatives to the high-voltage ratings listed in Tables 1 and 2.

The rated voltage should be the midtap voltage, and all performance characteristics shall be based on the rated voltage.

Four rated kilovolt-ampere equally-spaced voltage taps, two above rated voltage and two below rated voltage, should be provided for high voltages selected from Table 5. The total tap voltage range should not exceed 10%.

Table 5— Range of Other High-Voltage Ratings

Basic Lightning Impulse Insulation Level (BIL) (kV)	Range of Other Voltage Ratings (Line-to-Line) (volts)
20	2 160– 2500
30	2 501– 7 200
45	7 201– 8320
60	8 321–13 800
95	13 801–18 000*
110	18 001*–23 000
125	23 001–27 600
150	27 601*–34 500

NOTES:

- 1 — All voltages are Δ .
- 2 — Voltages separated by a dash indicate that all intervening voltages are included.
- 3 — It is suggested that when voltages higher than those listed in ANSI/IEEE C57.12.01-1979, Table 3, or grounded-Y voltages are involved, the surge protection be reviewed (in accordance with ANSI/IEEE C57.12.01-1979, Table 3, and ANSI C62.2-1980) and appropriate changes made in BIL, if necessary.

*.Nonpreferred voltage, as listed in ANSI C84.1-1977 and ANSI C84.1a-1980.

The percent tap voltage range shall be calculated as follows:

Percent tap voltage range

$$= \frac{(\text{maximum tap voltage} - \text{minimum tap voltage})100}{\text{rated tap voltage}}$$

8.4.3 Y-Connected High-Voltage Windings with Δ -Connected Low-Voltage Windings

NOTE — See ANSI/IEEE C57.105-1978 for problems that may result if the high-voltage neutral is grounded with the high voltage Y-connected and the low-voltage Δ -connected. (For Y-Y connected transformers, see 8.5.)

8.4.3.1

When specified, three-phase transformers with high voltage rated in accordance with Table 5 shall be furnished. The neutral insulation shall be in accordance with ANSI/IEEE C57.12.01-1979.

8.4.3.2

The angular displacement between high-voltage and low-voltage terminal voltages of Y- Δ connected three-phase transformers shall be 30 degrees, and the phasor relation shall be as shown in Fig. 5.

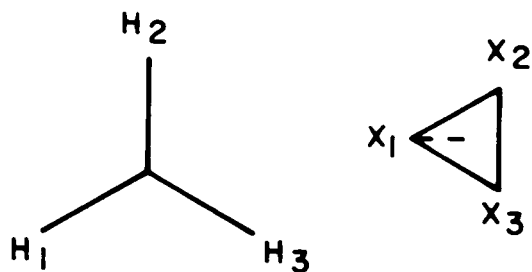

Figure 5— Y-Δ Connection

8.5 Y-Y Connected Transformers

8.5.1 Kilovolt-Ampere, Voltage, and BIL Combinations

When specified, Y-Y connected transformers shall be furnished with the kilovolt-ampere and voltage combinations described in Table 6. Basic lightning impulse insulation levels shall be furnished as described in Tables 3 and 7.

NOTE — ANSI/IEEE C57.105-1978 includes extensive discussion of Y-Y connection characteristics.

Table 6— Range of Kilovolt-Ampere and Voltage Ratings for Three-Phase (GA) Transformers Connected Y-Y

Rated High Voltage (volts)	Kilovolt-Ampere Ratings (kVA)		
	Low Voltage 208Y/120	Low Voltage 480Y/277	Low Voltage 4160GrdY/2400
4 160GrdY/2 400	750-1000	750-1500	-
12 000GrdY/6 930	750-1000	750-2500	750-5000
12 470GrdY/7 200	750-1000	750-2500	750-5000
13 200GrdY/7 620	750-1000	750-2500	750-5000
13 800GrdY/7 970	750-1000	750-2500	750-5000
22 860GrdY/13 200	750-1000	1000-2500	1500-5000
24 940GrdY/14 400	750-1000	1000-2500	1500-5000
34 500GrdY/19 920	750-1000	1000-2500	1500-5000

NOTE — Kilovolt-ampere ratings separated by a dash indicate that all intervening ratings specified in 4.1.2 are included

Table 7— High-Voltage Line Terminal Insulation Levels (Three-Phase, Y–Y Connected)

Rated High-Voltage (volts) (Note 1)	Basic Lightning Impulse Insulation Level (BIL) (kV)	Low-Frequency Voltage Insulation Level, (kV, rms) (Notes 1, 2)
4 160GrdY/2 400	20	10
12 000GrdY/6 930	60	10
12 470GrdY/7 200	60	10
13 200GrdY/7 620	60	10
13 800GrdY/7 920	60	10
22 860GrdY/13 200	95	10
24 940GrdY/14 400	110	10
34 500GrdY/19 920	125	10

NOTES:

- 1 — Neutrals are insulated, for low-frequency applied voltage test equal to that of winding line terminal or 10 kV, whichever is lower.
- 2 — Windings shall be capable of withstanding an induced voltage test of two times rated voltage (with neutral grounded) from line terminals to ground and between line terminals, in accordance with ANSI/IEEE C57.12.91-1979.

8.5.2 Unsymmetrical Excitation or Loading

Unsymmetrical excitation or loading of Y–Y connected units may cause heating of their tanks in excess of that which would be produced by balanced conditions. To reduce the probability of this tank heating, such units shall be provided, when specified, with a construction that will not cause magnetic core saturation when 33% zero-sequence voltage is applied.

8.5.3 Angular Displacement of Y–Y Connected Transformers

The angular displacement between high-voltage and low-voltage terminal voltages of three-phase transformers with Y–Y connections shall be 0 degrees, and the phasor relation shall be as shown in Fig. 6.

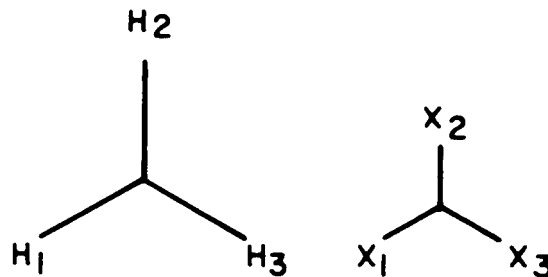
**Figure 6— Y–Y Connection****8.5.4 Neutral Connections**

For Y–Y connected units, the high-voltage neutral shall be brought out through a separate bushing and grounded externally.

8.6 Increased Neutral Insulation

When specified, increased neutral insulation shall be provided for ratings which normally have reduced neutral insulation, but shall not exceed the insulation level of the line terminals of the winding involved.

8.7 Other Basic Lightning Impulse Insulation Levels (BILs)

When specified, other basic impulse insulation levels shall be provided in accordance with Table 8.

Table 8— Other Basic Lightning Impulse Insulation Levels (BILs) Applicable to Windings

BIL* (kV)	Other BIL (kV)
20	30, 45
30	45, 60
45	60, 95
60	95, 110
95	110, 125
110	125, 150
125	150

*BILs corresponding to rated voltages listed in Tables 2, 3, 5, or 7 of this publication, or Table 3 of ANSI/IEEE C57.12.01-1979.

9. Other Construction (See Fig. 2)

9.1 High-Voltage Connection Arrangements

9.1.1

When specified, high-voltage terminals or leads shall be located in segment 3.

9.1.2

When specified, high-voltage terminals shall be provided on the cover in segment 3 or at the top of the end walls in segments 2 or 4.

9.1.3

When an air-filled terminal compartment is specified, it shall be located adjacent to segment 2 or 4. When the transformer high voltage is connected grounded Y, a removable ground strap shall be provided between the neutral terminal and a ground pad.

9.1.4

When a flange for connection to switchgear is specified, it shall be located adjacent to segment 2 or 4.

9.1.5

When a fused or unfused air interrupter switch or a current-limiting fuse is specified, it shall be located adjacent to segment 2 or 4.

9.1.6

When specified, provision shall be made in segment 1 or 3 for connection to cables.

NOTE — Design limitations may preclude placing both high-voltage and low-voltage cables together in a single segment.

9.1.7

When specified, a second ground pad as described in 5.10.4 shall be provided and located in the same segment as the high-voltage compartment.

9.2 Low-Voltage Connection Arrangements

9.2.1

When specified, low-voltage terminals or leads shall be located in segment 1.

9.2.2

When specified, low-voltage terminals shall be located on the cover in segment 1, or at the top of the end walls in segments 2 or 4.

9.2.3

When an air-filled terminal compartment is specified, it shall be located adjacent to segment 2 or 4. When the transformer low voltage is connected grounded Y, a removable ground strap shall be provided between the neutral terminal and a ground pad.

9.2.4

When a flange for connection to switchgear is specified, it shall be located adjacent to segment 4.

9.2.5

When a circuit breaker panel is specified, it shall be located adjacent to segment 2 or 4.

9.3 Surge Arresters

When high-voltage or low-voltage surge arresters are specified, they shall be provided with connections to ground.

9.4 Unit Substation Application

When specified for application as part of a unit substation, the arrangement of terminals for “standard” and “reverse” units (or “right-” and “left-hand”) shall be as described in ANSI C57.12.70-1978.

The tap changer of a “reverse” unit may be located at the opposite position on the transformer as compared to the location of a “standard” unit.

9.5 Pressure Alarm Switch

When specified, a pressure alarm switch shall be furnished to actuate an alarm (furnished by the user) when the pressure deviates from the manufacturer's design range. The pressure alarm switch shall be threaded with a 1/4-inch NPT female thread in accordance with ANSI B2.1-1968. The pressure alarm switch shall be located on the front wall in segment 1.

9.6 High-Temperature Alarm Switch

When specified, a high-temperature alarm switch shall be furnished and set by the manufacturer to provide an alarm in the event of excessive temperature.

9.7 Current Transformers (or Provision for Their Addition in the Future)

When specified, current transformers shall be provided and shall be in accordance with ANSI/IEEE C57.13-1978. There shall be a maximum of two per line. Two secondary leads per current transformer shall be brought to a terminal block. Provision for short-circuiting shall be supplied.

9.7.1

When specified, single-ratio current transformers with relay accuracy class shall be provided.

9.7.2

When specified, current transformers shall be multiratio with relay accuracy class (full winding) and taps as specified by ANSI/IEEE C57.13.1978.

9.8 Terminal Blocks

When specified, enclosed terminal blocks shall be provided and located in segment 1 or in the low-voltage segment.

9.8.1

A terminal block shall be provided for alarm circuits.

9.8.2

A terminal block shall be provided for current transformer secondaries allowing for two leads per current transformer.

9.9 Contacts

Nongrounded contacts for instruments and alarms shall be suitable for interrupting:

- 1) 0.02-ampere direct-current inductive load;
- 2) 0.20-ampere direct-current noninductive load;
- 3) 2.5-ampere alternating current load (either noninductive or inductive);
- 4) 250 volts minimum in all cases.

10. Other Tests

When specified, other tests shall be made in accordance with ANSI/IEEE C57.12.01-1979.